

TPS Pallet Truck Scales

General Specifications

- Display 52mm LCD display, white LED backlight
- Capacities 2t
- Keyboard 7 keys (Mechanical keyboard)
- Housing Mild steel
- Max. Divisions 4,000d
- ADC Sigma delta
- ADC update $\leq 1/10$ second
- Operating Temp. $-10^{\circ}\text{C} \sim +40^{\circ}\text{C}$
- Power AC adapter (12V/500mA), Internal rechargeable battery (lead acid 6V/10Ah)
- Gross Weight 160kg
- Packing carton packing, dimension 0.82m^3



4 models available:

- TPS-I Non Approved, 2000kg x 0.5kg
- TPS-I-EC OIML Approved 2000kg x 1kg
- TPS-II Non Approved 2000kg x 0.5kg with inbuilt thermal printer
- TPS-II-EC OIML Approved 2000kg x 1kg with inbuilt thermal printer

- Instant weight readings are available as soon as the forks are raised
- Applications: 1. Weighing unit conversion 2. Net/gross shift 3. Tare
- Easy access junction box
- Rugged construction for long life
- Rechargeable battery provides up to 60 hours of continuous use (without backlight)

www.scalesearch.co.uk

TPS Pallet Truck Scales

Model Name	Capacity	Readability	Division	Approx. weight	Approval
TPS-I	2t	0.5kg	4,000d	160kg	CE
TPS-I-EC	2t	1kg	2,000e	160kg	CE, OIML
TPS-II	2t	0.5kg	4,000d	160kg	CE
TPS-II-EC	2t	1kg	2,000e	160kg	CE, OIML

Dimensions(mm)

	a	b	c
Narrow fork (Europe)	555mm	195mm	1160mm

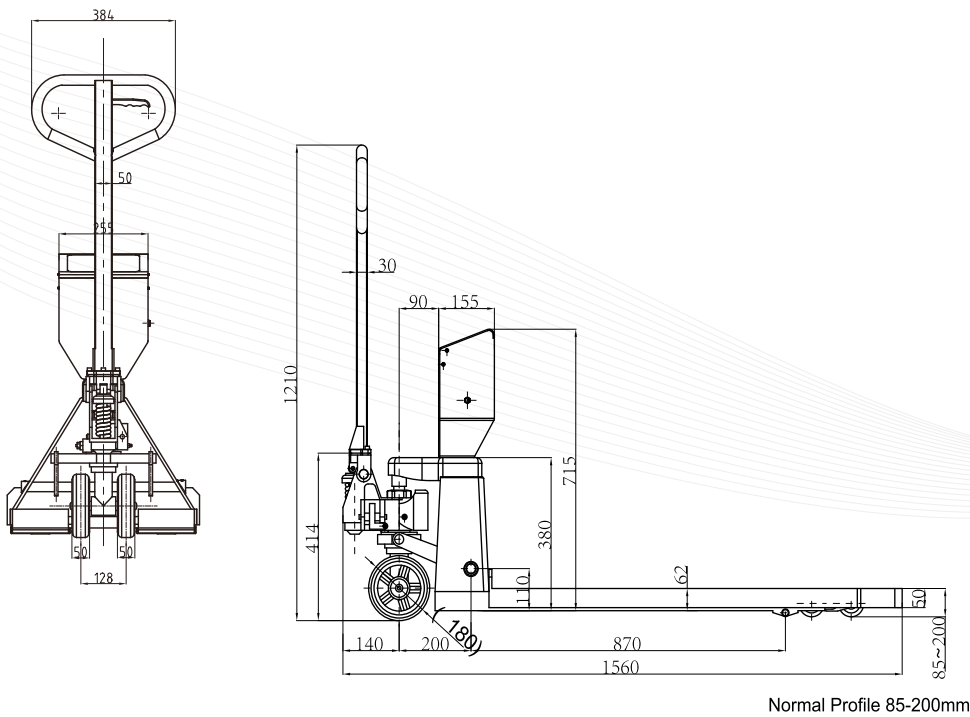

Print formats

3	61.6kg
3	61.6kg
No.	4
G.W.	61.6kg
N.W.	61.6kg
No.	5
N.W.	61.6kg
TOTAL	369.4kg
No.	6
Time	11:44:03
Date	2026/03/30
Date	2026/03/30
Time	11:43:28
No.	6
N.W.	61.4kg
TOTAL	369.4kg
Date	2026/03/30
Time	11:40:20
	61.6kg