



### TECHNICAL DATA

- ◆ External resolution.....1/30,000(QHW)
- ◆ Display.....24mm backlit LCD
- ◆ Pan size.....230mm×300mm
- ◆ Keyboard.....7 keys embossed membrane keyboard
- ◆ Operate temp.....0°C ~ +40°C
- ◆ ADC.....sigma delta
- ◆ ADC update.....≤ 1/10 second
- ◆ Internal counts.....600,000
- ◆ Rating.....Mains lead and  
Internal rechargeable battery (6V/4Ah)

### FEATURES

- ◆ 24mm digits high LCD backlit display
- ◆ Function include check weighting, counting, percentage, accumulate and weighing units conversion
- ◆ Rechargeable battery operation
- ◆ Check weighing function (user can set hi/low limit for weighing, counting and percentage)
- ◆ Auto backlight display
- ◆ RS-232C communication port

### DIMENSIONS (mm)

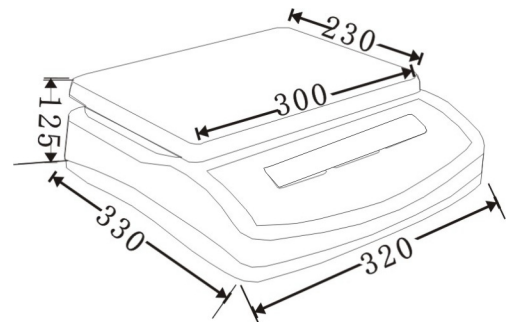

### SPECIFICATIONS

| MODEL        | QHW-3         |  | QHW-6 |  | QHW-15 |  | QHW-30 |  |
|--------------|---------------|--|-------|--|--------|--|--------|--|
| Capacity     | 3kg           |  | 6kg   |  | 15kg   |  | 30kg   |  |
| Readability  | 0.1g          |  | 0.2g  |  | 0.5g   |  | 1g     |  |
| Tare range   | 3kg           |  | 6kg   |  | 10kg   |  | 30kg   |  |
| Pan size     | 230mm x 300mm |  |       |  |        |  |        |  |
| Gross weight | 5.1kg         |  |       |  |        |  |        |  |