



TECHNICAL DATA

- ◆ External resolution... 1/15,000
- ◆ Display.....52mm Backlit LCD
- ◆ Keyboard..... 7 keys mechanical switch
- ◆ Operate temp.....0°C ~ +40°C
- ◆ ADC.....sigma delta
- ◆ ADC update.....≤ 1/10 second
- ◆ Power.....AC adapter (9V/800mA)
Rechargeable battery (6V/4Ah)

FEATURES

- ◆ Easy to use - front panel configuration
- ◆ 52mm LCD display, attached LED backlight
- ◆ Function include check weighting, weight unit conversion or net/gross shift, accumulate
- ◆ Battery provide up to 90 hours of continuous use.
- ◆ Optional RS-232 interface
- ◆ Optional analog output (4V~20mA / 0 ~10V)
- ◆ Hi / ok / lo , red / green / red , LED 'S
- ◆ Counting with selectable sample quantities

DIMENSIONS (mm)

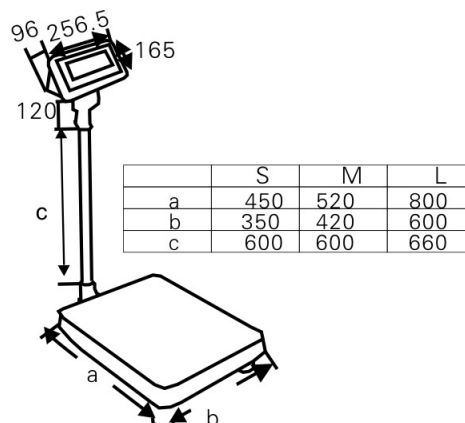

SPECIFICATIONS

MODEL	MBW	M	LBW	L
Display	52mm LCD display, attached backlight			
Housing	Indicator: ABS plastic Pan: Stainless Steel Top Plate platform: Aluminium (M) or Steel (L)			
Max. Divisions	15,000d			
Keypad	7 keys			
Power	AC adapter (9V/800mA) rechargeable battery (6V/4Ah)			
Gross weight	17.8kg		58kg	